

**Constant current independent dimmable driver**  
**DEL Series suffix d(DALI-2+PUSH)**

Rev. BK-DEL042-1100Ad

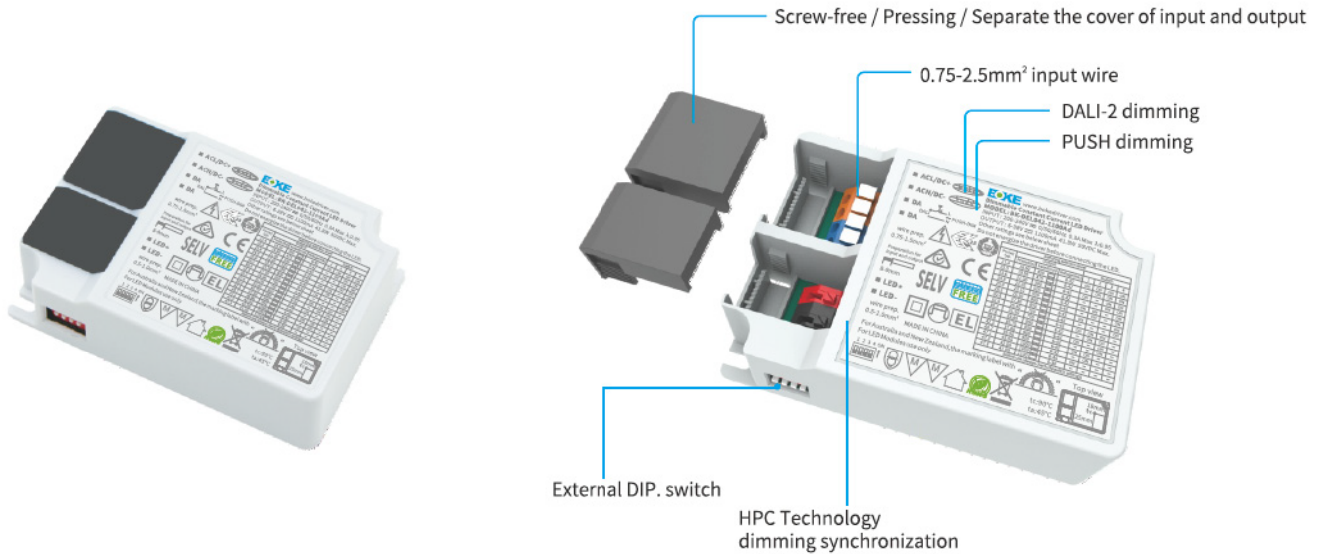

**Features**

- Support DALI-2+PUSH(switchDIM) dimming mode
- 16-level current output can be realized through external DIP-switch, easier to adjust the luminaire power
- Soft dimming and flicker-free at any brightness, meets the new requirements of ErP certification
- Using HPC patented technology at any dimming level, the current output between drivers is the same
- Dimming range 1%~100%, output current accuracy 2%
- Standby power input<0.5W, meets the ErP requirements of new certification
- High PF, high efficiency, low THD
- Screw-free and pressing type strain relief, easier install
- Independent input and output strain relief, stronger wiring
- Supports 0.75-2.5mm<sup>2</sup> input wires, stronger wiring
- Intelligent LED hot-plug protection function
- SELV and Class II design, suitable for use inside of the light
- Passed ENEC-TUV,CE,RCM,CCC,DALI-2 and other certifications
- IP20 protection grade, indoor use
- Nominal life-time up to 100,000 h
- 5-year guarantee

**Interfaces**

- DALI-2(DALI-2 DT6)
- PUSH(PUSH-DIM)

**Functions**

- Support central emergency application (dimming normal in DC input)
- Support self-contained emergency application
- Protective features (short-circuit, overload,no-load, hot plug-in protection )

**Suitable for lights**

- Suitable for lights with independent drivers such as downlights, spotlights, panel lights, etc
- Not suitable for lights with built-in drivers

**Typical applications**

- LED indoor lighting
- LED office lighting
- LED commercial lighting



### Model coding rules of DEL series

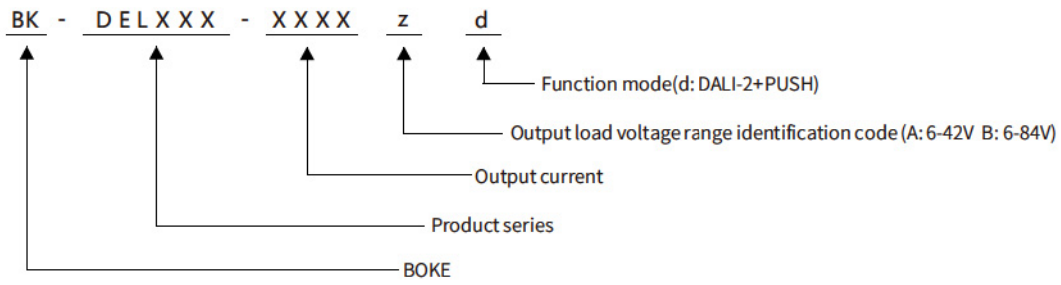

### Order selection table of DEL series(just suffix d, 30W/42W/60W)

Model	Input voltage	Output power	Output voltage	Output current	Dimension	Article number
BK-DEL030-0800Ad	200-240VAC	30.4W	6-42VDC	0.25-0.80A	L103*W68.5*H30.5mm	B-DEL030-HA1001Ad
BK-DEL042-0800Bd	200-240VAC	41.6W	6-84VDC	0.25-0.80A	L103*W68.5*H30.5mm	B-DEL042-HA1002Bd
BK-DEL042-1100Ad	200-240VAC	41.8W	6-42VDC	0.45-1.10A	L103*W68.5*H30.5mm	B-DEL042-HA1001Ad
BK-DEL060-2000Ad	200-240VAC	60.0W	6-42VDC	0.80-2.00A	L123.5*W79.5*H31mm	B-DEL060-HA1001Ad

**Technical data**

Product model	BK-DEL030-0800Ad
<b>Output parameters</b>	
Regulation method	Constant Current
Rated output current	0.25-0.8A
Rated output voltage	6-42V
Rated output power	30.4W Max
Output current adjustment	DIP S.W(16 levels)
Output current ripple LF	±2%
Output current accuracy	±2%
Linear regulation	±1%
Load regulation	±1%
No load output voltage	50V
Flicker-free(typical)	Modulation depth =0.1%, Pst LM = 0.001, SVM = 0.004,(The above parameters are obtained from testing the panel lights)
<b>Input parameters</b>	
Rated input voltage	200-240VAC 200-240VDC
Rated input voltage	180-264VAC 180-264VDC
Input voltage shock	<380 VAC, 1 h
Input current	<0.22A (AC input)
Input frequency	0/50/60Hz
Input power factor	>0.95 (230V AC & Full load), >0.90(230V AC & load>50%)
Input THD	7% (230V AC & Full load)
Efficiency(typical)	87% (230V AC & Full load)
In-rush current	3.95A peak ,180us duration(50 % Ipeak), see the description below for details
Start/Switchover/Turn off	<0.6s(AC start),<0.6s(DC start),<0.3s(AC/DC switchover),<0.5s(Turn off)
Switching cycles	> 50,000 switching cycles
Power consumption	Full load(Pmax):30.4W, No load(Pno): N/A, On stand-by(Psb) : <0.5W, Network stand-by(Pnet) : N/A
<b>Safety</b>	
Withstand voltage	I/P-O/P(LED):3750V AC, O/P(LED)-O/P(DIM):500V AC, I/P-O/P(DIM):500V AC, I/P-DALI: 500V AC
Mains surge capability	L-N:2KV
Leakage current	<0.7mA (230V AC & Full load)
Isolation resistance	I/P-O/P:100MΩ/500Vdc/25°C/70% RH
<b>Control interface</b>	
DALI dimming port	Voltage range: 9.5-22.5V, typical 16V, interface current consumption: 1.8mA
PUSH dimming port	Voltage range: 180-264V 47/63Hz
1-10V 3in1 dimming port	N/A
Auxiliary power supply	N/A
Dimming range	1%-100%
Dimming drive mode	AM(amplitude modulation)
<b>Emergency support</b>	
Central emergency system	Supported(dimming normal in DC input)
Self-contained emergency	Supported
<b>Environment &amp; Life time</b>	
Operating temperature	Ta=-20-45°C
Case temperature	Tc=90°C
Operating humidity	5-85% RH, not condensed
Storage temp./humidity	-40-80°C, 5-85% RH, not condensed
IP grade	IP20
MTBF	500,000H,MIL-HDBK-217F(25°C)
Life-time	Nominal life-time up to 100,000 h, see the description below for details
Vibration resistant	10~500Hz,5G 12min./1cycle,period for 72min. each along X,Y,Z axes
Acoustic Noise	<25dB(30cm, Full load)
Environmental protection	RoHS
<b>Certifications and standards</b>	
Certified	ENEC-TUV, RCM, EMC, CE, CCC, DALI-2
Safety	EN61347-1, EN61347-2-13, EN62384
EMC	EN55015, EN61000-3-2, EN61000-3-3, EN61000-4-2,3,4,5,6,8,11, EN61547
DALI-2	IEC 62386-101(DALI-2), IEC 62386-102(DALI-2), IEC 62386-207(DALI-2)
EL	Compatible IEC 61347-2- 13 Annex J , compatible with EN 60598-2-22 and EN 50172
RF	N/A

**Remarks**

- 1.By default, all parameter are measured at 230VAC input, full load and 25°C of ambient temperature.
- 2.The driver can not be installed inside the light. when the driver is used with the light, the EMC of the whole light needs to be tested.

**Technical data**

Product model	BK-DEL042-0800Bd
<b>Output parameters</b>	
Regulation method	Constant Current
Rated output current	0.25-0.8A
Rated output voltage	6-84V
Rated output power	41.6W Max
Output current adjustment	DIP S.W(16 levels)
Output current ripple LF	±2%
Output current accuracy	±2%
Linear regulation	±1%
Load regulation	±1%
No load output voltage	100V
Flicker-free(typical)	Modulation depth =0.1%, Pst LM = 0.001, SVM = 0.001,(The above parameters are obtained from testing the panel lights)
<b>Input parameters</b>	
Rated input voltage	200-240VAC 200-240VDC
Rated input voltage	180-264VAC 180-264VDC
Input voltage shock	<380 VAC, 1 h
Input current	<0.3A (AC input)
Input frequency	0/50/60Hz
Input power factor	>0.95 (230V AC & Full load), >0.90(230V AC & load>50%)
Input THD	7% (230V AC & Full load)
Efficiency(typical)	89% (230V AC & Full load)
In-rush current	8A peak ,296us duration(50 % Ipeak), see the description below for details
Start/Switchover/Turn off	<0.6s(AC start),<0.6s(DC start),<0.3s(AC/DC switchover),<0.5s(Turn off)
Switching cycles	> 50,000 switching cycles
Power consumption	Full load(Pmax):41.6W, No load(Pno): N/A, On stand-by(Psb) : <0.5W, Network stand-by(Pnet) : N/A
<b>Safety</b>	
Withstand voltage	I/P-O/P(LED):3750V AC, O/P(LED)-O/P(DIM):500V AC, I/P-O/P(DIM):500V AC, I/P-DALI: 500V AC
Mains surge capability	L-N:2KV
Leakage current	<0.7mA (230V AC & Full load)
Isolation resistance	I/P-O/P:100MΩ/500Vdc/25°C/70% RH
<b>Control interface</b>	
DALI dimming port	Voltage range: 9.5-22.5V, typical 16V, interface current consumption: 1.8mA
PUSH dimming port	Voltage range: 180-264V 47/63Hz
1-10V 3in1 dimming port	N/A
Auxiliary power supply	N/A
Dimming range	1%-100%
Dimming drive mode	AM(amplitude modulation)
<b>Emergency support</b>	
Central emergency system	Supported(dimming normal in DC input)
Self-contained emergency	Supported
<b>Environment &amp; Life time</b>	
Operating temperature	Ta=-20-45°C
Case temperature	Tc=90°C
Operating humidity	5-85% RH, not condensed
Storage temp./humidity	-40-80°C, 5-85% RH, not condensed
IP grade	IP20
MTBF	500,000H,MIL-HDBK-217F(25°C)
Life-time	Nominal life-time up to 100,000 h, see the description below for details
Vibration resistant	10~500Hz,5G 12min./1cycle,period for 72min. each along X,Y,Z axes
Acoustic Noise	<25dB(30cm, Full load)
Environmental protection	RoHS
<b>Certifications and standards</b>	
Certified	ENEC-TUV, RCM, EMC, CE, CCC, DALI-2
Safety	EN61347-1, EN61347-2-13, EN62384
EMC	EN55015, EN61000-3-2, EN61000-3-3, EN61000-4-2,3,4,5,6,8,11, EN61547
DALI-2	IEC 62386-101(DALI-2), IEC 62386-102(DALI-2), IEC 62386-207(DALI-2)
EL	Compatible IEC 61347-2- 13 Annex J, compatible with EN 60598-2-22 and EN 50172
RF	N/A

**Remarks**

- 1.By default, all parameter are measured at 230VAC input, full load and 25°C of ambient temperature.
- 2.The driver can not be installed inside the light. when the driver is used with the light, the EMC of the whole light needs to be tested.

**Technical data**

Product model	BK-DEL042-1100Ad
<b>Output parameters</b>	
Regulation method	Constant Current
Rated output current	0.45-1.1A
Rated output voltage	6-42V
Rated output power	41.8W Max
Output current adjustment	DIP S.W(16 levels)
Output current ripple LF	±2%
Output current accuracy	±2%
Linear regulation	±1%
Load regulation	±1%
No load output voltage	50V
Flicker-free(typical)	Modulation depth =0.1%, Pst LM = 0.003, SVM = 0.005,(The above parameters are obtained from testing the panel lights)
<b>Input parameters</b>	
Rated input voltage	200-240VAC 200-240VDC
Rated input voltage	180-264VAC 180-264VDC
Input voltage shock	<380 V AC, 1 h
Input current	<0.3A (AC input)
Input frequency	0/50/60Hz
Input power factor	>0.95 (230V AC & Full load), >0.90(230V AC & load>50%)
Input THD	7% (230V AC & Full load)
Efficiency(typical)	88% (230V AC & Full load)
In-rush current	7.9A peak ,304us duration(50 % Ipeak), see the description below for details
Start/Switchover/Turn off	<0.6s(AC start),<0.6s(DC start),<0.3s(AC/DC switchover),<0.5s(Turn off)
Switching cycles	> 50,000 switching cycles
Power consumption	Full load(Pmax):41.8W, No load(Pno): N/A, On stand-by(Psb) : <0.5W, Network stand-by(Pnet) : N/A
<b>Safety</b>	
Withstand voltage	I/P-O/P(LED):3750V AC, O/P(LED)-O/P(DIM):500V AC, I/P-O/P(DIM):500V AC, I/P-DALI: 500V AC
Mains surge capability	L-N:2KV
Leakage current	<0.7mA (230V AC & Full load)
Isolation resistance	I/P-O/P:100MΩ/500Vdc/25°C/70% RH
<b>Control interface</b>	
DALI dimming port	Voltage range: 9.5-22.5V, typical 16V, interface current consumption: 1.8mA
PUSH dimming port	Voltage range: 180-264V 47/63Hz
1-10V 3in1 dimming port	N/A
Auxiliary power supply	N/A
Dimming range	1%-100%
Dimming drive mode	AM(amplitude modulation)
<b>Emergency support</b>	
Central emergency system	Supported(dimming normal in DC input)
Self-contained emergency	Supported
<b>Environment &amp; Life time</b>	
Operating temperature	Ta=-20-45°C
Case temperature	Tc=90°C
Operating humidity	5-85% RH, not condensed
Storage temp./humidity	-40-80°C, 5-85% RH, not condensed
IP grade	IP20
MTBF	500,000H,MIL-HDBK-217F(25°C)
Life-time	Nominal life-time up to 100,000 h, see the description below for details
Vibration resistant	10~500Hz,5G 12min./1cycle,period for 72min. each along X,Y,Z axes
Acoustic Noise	<25dB(30cm, Full load)
Environmental protection	RoHS
<b>Certifications and standards</b>	
Certified	ENEC-TUV, RCM, EMC, CE, CCC, DALI-2
Safety	EN61347-1, EN61347-2-13, EN62384
EMC	EN55015, EN61000-3-2, EN61000-3-3, EN61000-4-2,3,4,5,6,8,11, EN61547
DALI-2	IEC 62386-101(DALI-2), IEC 62386-102(DALI-2), IEC 62386-207(DALI-2)
EL	Compatible IEC 61347-2- 13 Annex J, compatible with EN 60598-2-22 and EN 50172
RF	N/A

**Remarks**

- 1.By default, all parameter are measured at 230VAC input, full load and 25°C of ambient temperature.
- 2.The driver can not be installed inside the light. when the driver is used with the light, the EMC of the whole light needs to be tested.

**Technical data**

Product model	BK-DEL060-2000Ad
<b>Output parameters</b>	
Regulation method	Constant Current
Rated output current	0.8-2.0A
Rated output voltage	6-42V
Rated output power	60W Max
Output current adjustment	DIP S.W(16 levels)
Output current ripple LF	±2%
Output current accuracy	±2%
Linear regulation	±1%
Load regulation	±1%
No load output voltage	50V
Flicker-free(typical)	Modulation depth =0.1%, Pst LM = 0.011, SVM = 0.006,(The above parameters are obtained from testing the panel lights)
<b>Input parameters</b>	
Rated input voltage	200-240VAC 200-240VDC
Rated input voltage	180-264VAC 180-264VDC
Input voltage shock	<380 V AC, 1 h
Input current	<0.4A (AC input)
Input frequency	0/50/60Hz
Input power factor	>0.95 (230V AC & Full load), >0.90(230V AC & load>50%)
Input THD	7% (230V AC & Full load)
Efficiency(typical)	89% (230V AC & Full load)
In-rush current	9.1A peak ,174us duration(50 % Ipeak), see the description below for details
Start/Switchover/Turn off	<0.6s(AC start),<0.6s(DC start),<0.3s(AC/DC switchover),<0.5s(Turn off)
Switching cycles	> 50,000 switching cycles
Power consumption	Full load(Pmax):60W, No load(Pno): N/A, On stand-by(Psb) : <0.5W, Network stand-by(Pnet) : N/A
<b>Safety</b>	
Withstand voltage	I/P-O/P(LED):3750V AC, O/P(LED)-O/P(DIM):500V AC, I/P-O/P(DIM):500V AC, I/P-DALI: 500V AC
Mains surge capability	L-N:2KV
Leakage current	<0.7mA (230V AC & Full load)
Isolation resistance	I/P-O/P:100MΩ/500Vdc/25°C/70% RH
<b>Control interface</b>	
DALI dimming port	Voltage range: 9.5-22.5V, typical 16V, interface current consumption: 1.8mA
PUSH dimming port	Voltage range: 180-264V 47/63Hz
1-10V 3in1 dimming port	N/A
Auxiliary power supply	N/A
Dimming range	1%-100%
Dimming drive mode	AM(amplitude modulation)
<b>Emergency support</b>	
Central emergency system	Supported(dimming normal in DC input)
Self-contained emergency	Supported
<b>Environment &amp; Life time</b>	
Operating temperature	Ta=-20-45°C
Case temperature	Tc=90°C
Operating humidity	5-85% RH, not condensed
Storage temp./humidity	-40-80°C, 5-85% RH, not condensed
IP grade	IP20
MTBF	500,000H,MIL-HDBK-217F(25°C)
Life-time	Nominal life-time up to 100,000 h, see the description below for details
Vibration resistant	10~500Hz,5G 12min./1cycle,period for 72min. each along X,Y,Z axes
Acoustic Noise	<25dB(30cm, Full load)
Environmental protection	RoHS
<b>Certifications and standards</b>	
Certified	ENEC-TUV, RCM, EMC, CE, CCC, DALI-2
Safety	EN61347-1, EN61347-2-13, EN62384
EMC	EN55015, EN61000-3-2, EN61000-3-3, EN61000-4-2,3,4,5,6,8,11, EN61547
DALI-2	EN 62386-101(DALI-2), EN 62386-102(DALI-2), EN 62386-207(DALI-2)
EL	Compatible IEC 61347-2- 13 Annex J , compatible with EN 60598-2-22 and EN 50172
RF	N/A

**Remarks**

- 1.By default, all parameter are measured at 230VAC input, full load and 25°C of ambient temperature.
- 2.The driver can not be installed inside the light. when the driver is used with the light, the EMC of the whole light needs to be tested.

Electrical values

**BK-DEL030-0800Ad**

Operating window

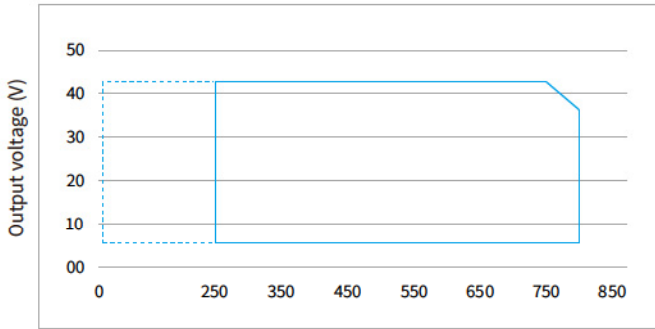

Output current(mA) — Operating window 100 %  
 - - - - - Operating window dimmed

Operating window

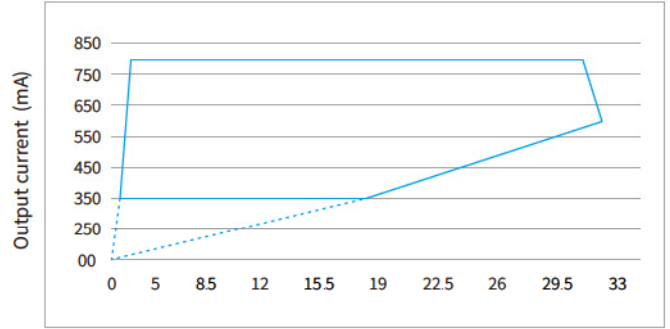

Output power(W) — Operating window 100 %  
 - - - - - Operating window dimmed

Efficiency vs load

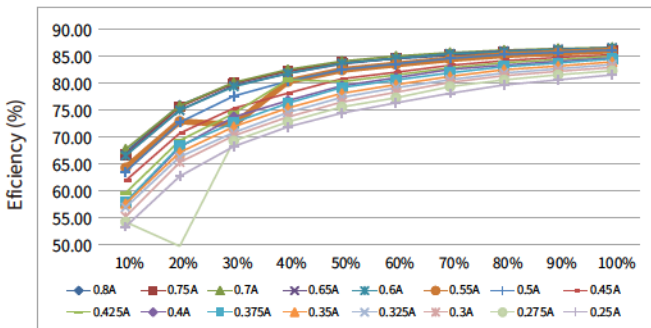

Load(%)

THD vs. Load

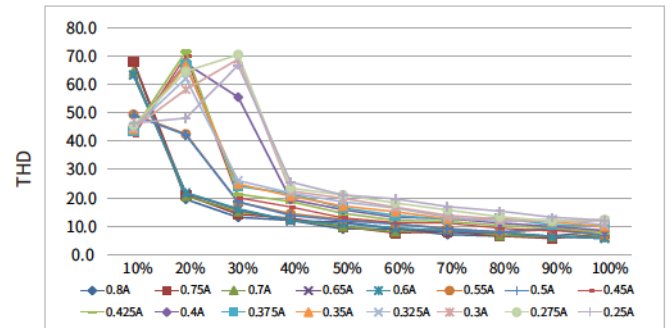

Load(%)

Power factor vs. Load

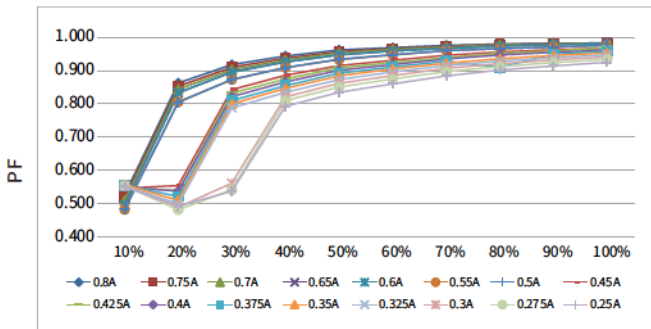

Load(%)

**BK-DEL042-0800Bd**

Operating window

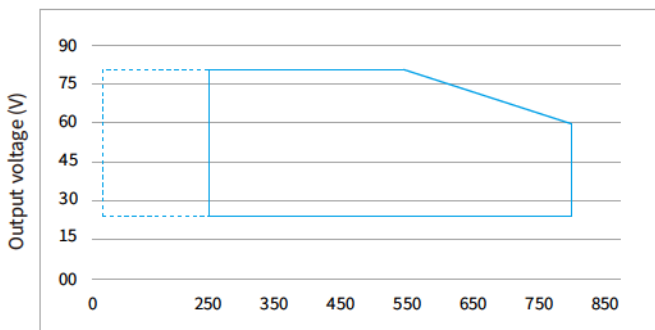

Output current(mA) — Operating window 100 %  
 - - - - - Operating window dimmed

Operating window

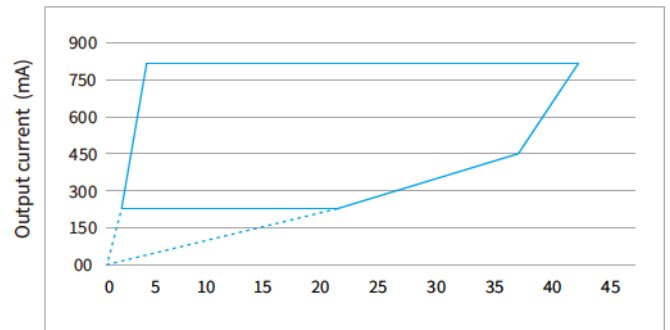

Output power(W) — Operating window 100 %  
 - - - - - Operating window dimmed

**BK-DEL042-0800Bd(Continue)**

Efficiency vs load

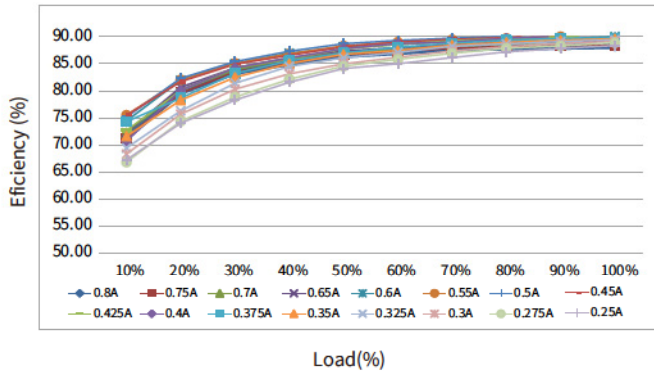

THD vs. Load

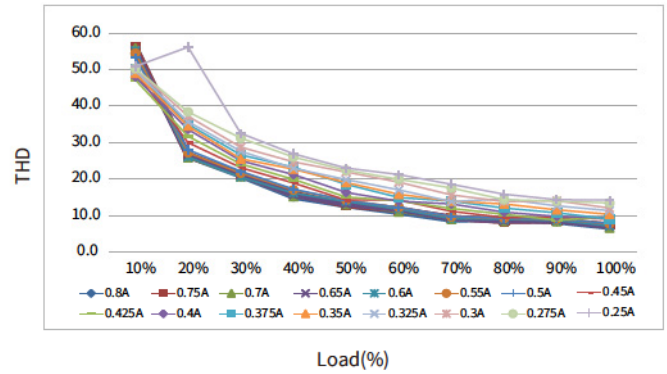

Power factor vs. Load

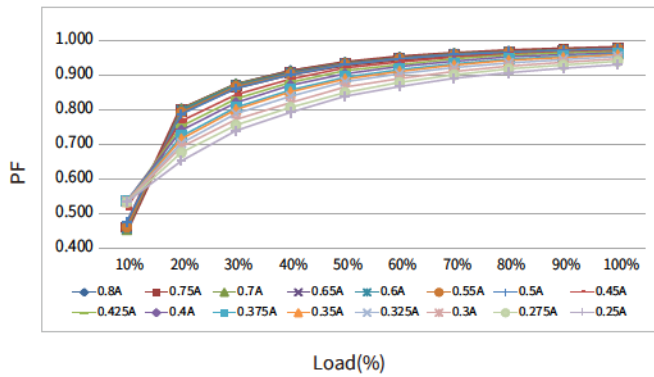

**BK-DEL042-1100Ad**

Operating window

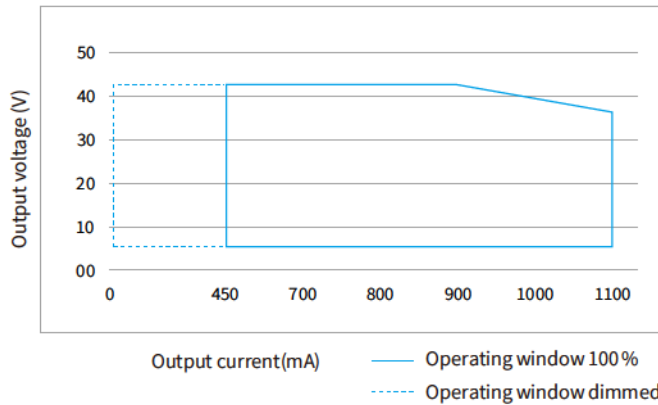

Operating window

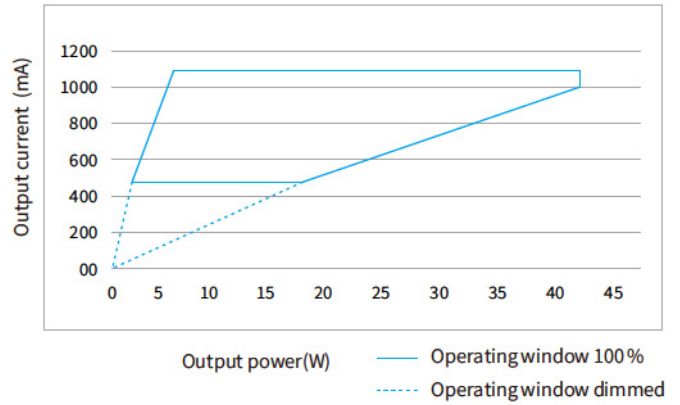

Efficiency vs load

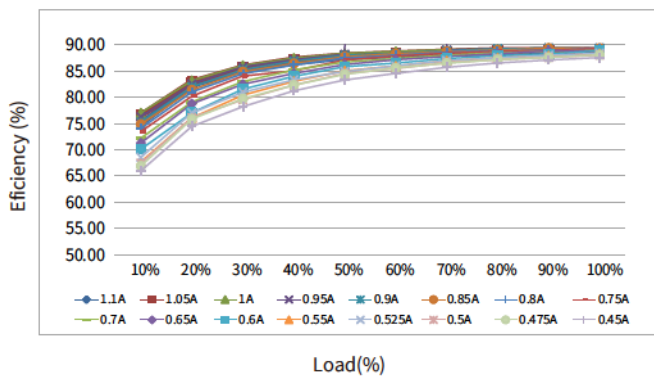

THD vs. Load

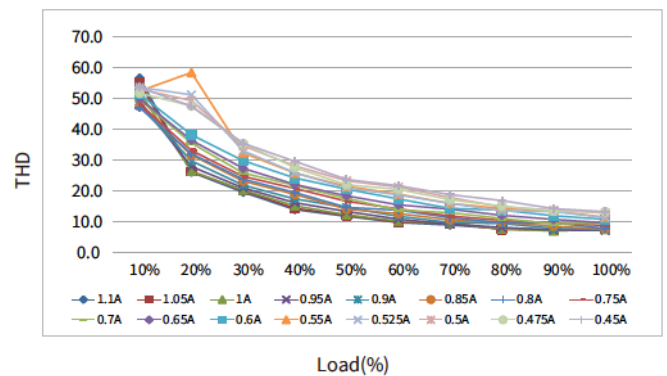



**BK-DEL042-1100Ad(Continue)**

Power factor vs. Load

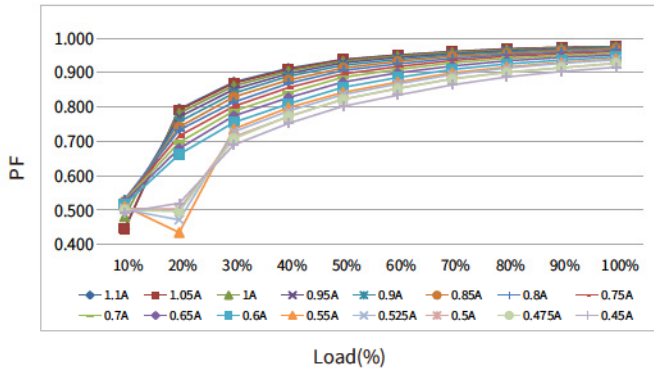

**BK-DEL060-2000Ad**

Operating window

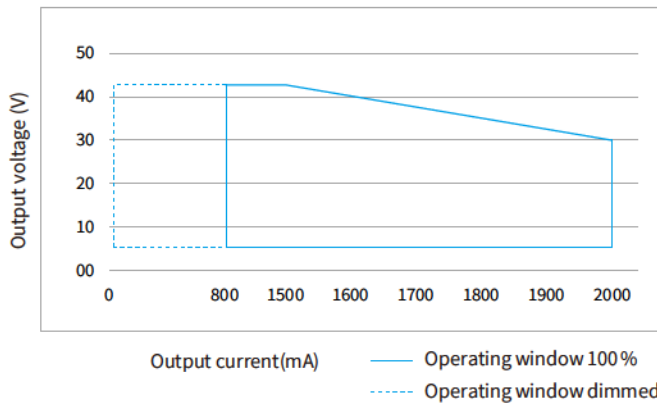

Operating window

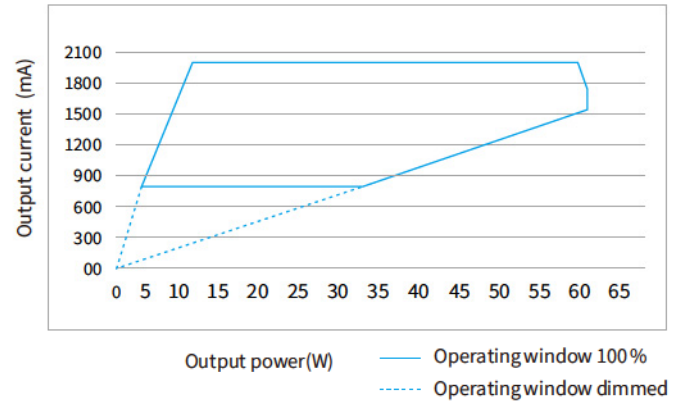

Efficiency vs load

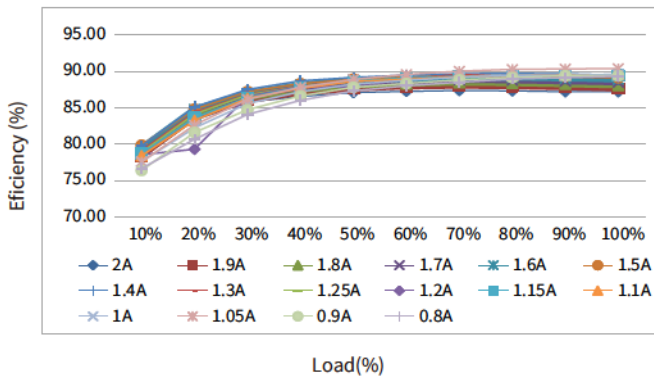

THD vs. Load

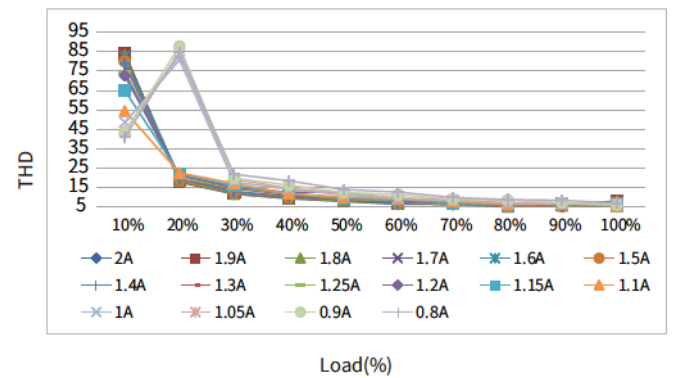

Power factor vs. Load

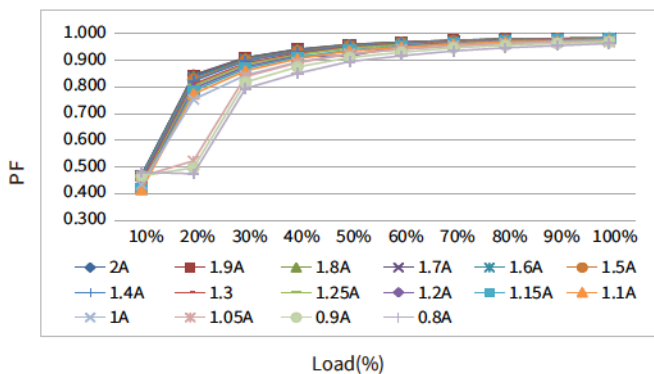

**Expected life-time**

**BK-DEL030-0800Ad**

Life-time vs. case temperature

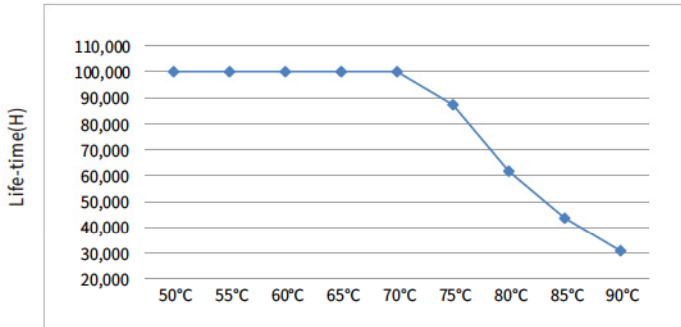

Case temperature(Tc)

**BK-DEL042-0800Bd**

Life-time vs. case temperature

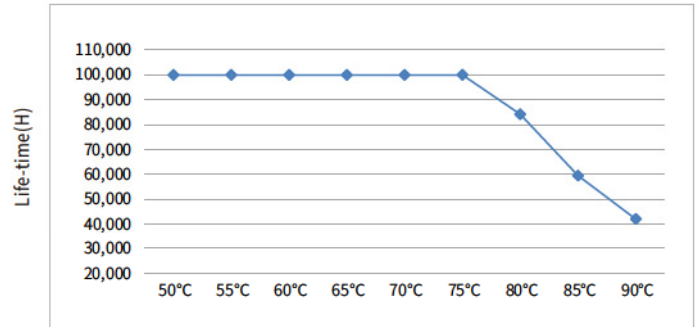

Case temperature(Tc)

**BK-DEL042-1100Ad**

Life-time vs. case temperature

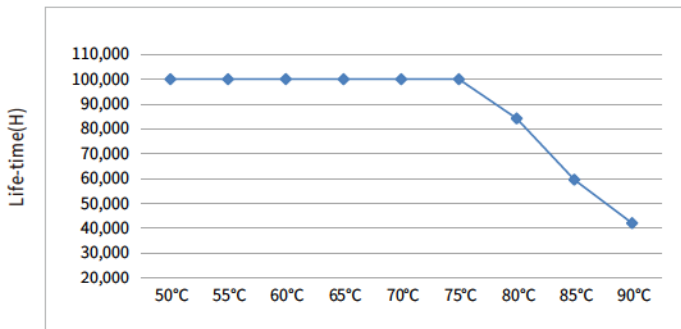

Case temperature(Tc)

**BK-DEL060-2000Ad**

Life-time vs. case temperature

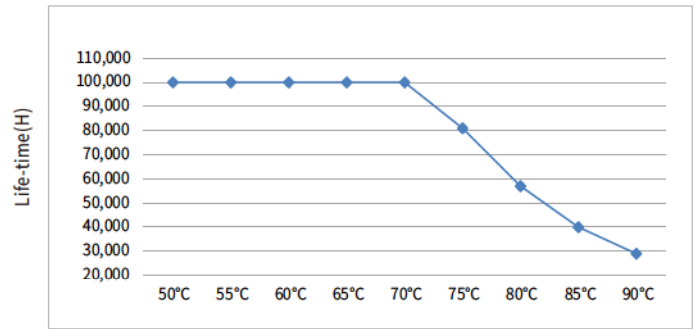

Case temperature(Tc)

- The life-time of the LED driver is shown in the figure above (calculated based on the 90% survival rate).
- The relation of tc to ta temperature depends also on the luminaire design.

## Surge

Model	I <sub>peak</sub>	T <sub>width</sub>	Condition	Relative number of MCB														
				B10	B13	B16	B20	B25	C10	C13	C16	C20	C25	D10	D13	D16	D20	D25
BK-DEL030-0800Ad	3.95A	180us	AC 230V, Full load, Cold start, T <sub>a</sub> ≤ 30°C, MCB is not installed side by side	46pcs	60pcs	73pcs	92pcs	114pcs	46pcs	60pcs	73pcs	92pcs	114pcs	46pcs	60pcs	73pcs	92pcs	114pcs
BK-DEL042-0800Bd	8A	296us		24pcs	31pcs	39pcs	48pcs	60pcs	34pcs	44pcs	54pcs	67pcs	84pcs	34pcs	44pcs	54pcs	67pcs	84pcs
BK-DEL042-1100Ad	7.9A	304us		24pcs	31pcs	38pcs	48pcs	60pcs	34pcs	44pcs	54pcs	67pcs	84pcs	34pcs	44pcs	54pcs	67pcs	84pcs
BK-DEL060-2000Ad	9.1A	174us		23pcs	29pcs	36pcs	45pcs	57pcs	23pcs	29pcs	36pcs	45pcs	57pcs	23pcs	29pcs	36pcs	45pcs	57pcs

### Remarks

- The number of drives mounted under different MCBs in the table is the maximum value. Please do not exceed this number during installation.
- Calculation uses typical values from ABB series S200 as a reference.
- Different brands and models of miniature circuit breakers, the number of drives mounted will be slightly different.
- If the ambient temperature of the MCB installation exceeds 30°C or multiple MCBs are installed side by side, the number of drives mounted will be reduced and the calculation needs to be recalculated.
- Electrician's usually consider Type B for household lighting and Type C for commercial lighting application.

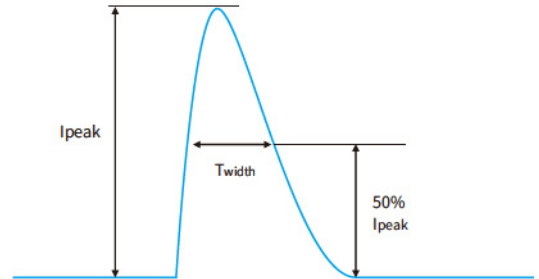

## Functions

### Output short-circuit behaviour

- In case of a short-circuit at the LED output, the LED output is switched off.
- After restart of the LED driver, the output will be activated again.
- The restart can either be done via mains reset or via interface (DALI, PUSH-DIM).

### Output no-load operation

- The LED driver will not be damaged in no-load operation.
- The output will be deactivated and is therefore free of voltage.
- If a LED load is connected, the device has to be restarted before the output will be activated again.
- The restart can either be done via mains reset or via interface (DALI, PUSH-DIM).

### Output overload protection

- If the output voltage range is exceeded the LED driver turns off the LED output.
- After restart of the LED driver the output will be activated again.
- The restart can either be done via mains reset or via interface (DALI, PUSH-DIM).

### Output hot plug-in

- For protection LED if plug the LED into the output of the powered driver, the LED will not on, the device has to be restarted.
- The restart can either be done via mains reset or via interface (DALI, PUSH-DIM).

**Label**

**ACL/DC+** **BOKE** www.bokedriver.com  
**Dimmable Constant Current LED Driver**  
**MODEL: BK-DEL030-0800Ad**  
**ACN/DC-**   
**INPUT:** 200-240V  $\approx$  0.50/60Hz 0.22A Max  $\lambda$ :0.95  
**OUTPUT:** 6-38V  $\approx$  800mA 30.4W 50VDC Max.  
 Other ratings see below sheet  
 Do not energize the driver before connecting the LED.

**DA**   
**DA**   
 wire prep. 0.75-1.5mm<sup>2</sup>  
 Preparation for input and output: 8-9mm  
**LED+**   
**LED-**   
 wire prep. 0.5-1.0mm<sup>2</sup> **MADE IN CHINA**

Pin(w) typ.	Prated(w)	Irated(mA)	Voltage(Vdc)	Switch			
				1	2	3	4
12.6	30.50	300	6-42	ON	ON	ON	ON
13.9	33.55	330	6-42	ON	ON	ON	ON
14.9	36.60	360	6-42	ON	ON	ON	ON
16.0	39.65	390	6-42	ON	ON	ON	ON
17.2	42.70	420	6-42	ON	ON	ON	ON
18.3	45.75	450	6-42	ON	ON	ON	ON
19.5	48.80	480	6-42	ON	ON	ON	ON
20.7	51.85	510	6-42	ON	ON	ON	ON
21.9	54.90	540	6-42	ON	ON	ON	ON
24.2	61.00	600	6-42	ON	ON	ON	ON
26.5	67.10	660	6-42	ON	ON	ON	ON
28.9	73.20	720	6-42	ON	ON	ON	ON
31.3	79.30	780	6-42	ON	ON	ON	ON
33.7	85.40	840	6-42	ON	ON	ON	ON
34.4	86.00	840	6-40	ON	ON	ON	ON
35.1	90.40	800	6-38	ON	ON	ON	ON

For Australia and New Zealand, the marking label with "M"   
 For LED Modules use only   
 tc:90°C ta:45°C

**DIP-switch & output current**

BK-DEL030-0800Ad

Pin	Irated	Voltage	1	2	3	4
12.6W	250mA	42VDC	ON	ON	ON	ON
13.9W	275mA	42VDC	--	ON	ON	ON
14.9W	300mA	42VDC	ON	--	ON	ON
16.0W	325mA	42VDC	--	--	ON	ON
17.2W	350mA	42VDC	ON	ON	--	ON
18.3W	375mA	42VDC	--	ON	--	ON
19.5W	400mA	42VDC	ON	--	--	ON
20.7W	425mA	42VDC	--	--	--	ON
21.9W	450mA	42VDC	ON	ON	ON	--
24.2W	500mA	42VDC	--	ON	ON	--
26.5W	550mA	42VDC	ON	--	ON	--
28.9W	600mA	42VDC	--	--	ON	--
31.3W	650mA	42VDC	ON	ON	--	--
33.7W	700mA	42VDC	--	ON	--	--
34.4W	750mA	40VDC	ON	--	--	--
35.1W	800mA	38VDC	--	--	--	--

**ACL/DC+** **BOKE** www.bokedriver.com  
**Dimmable Constant Current LED Driver**  
**MODEL: BK-DEL042-0800Bd**  
**ACN/DC-**   
**INPUT:** 200-240V  $\approx$  0.50/60Hz 0.3A Max  $\lambda$ :0.95  
**OUTPUT:** 6-52V  $\approx$  800mA 41.6W 100VDC Max.  
 Other ratings see below sheet  
 Do not energize the driver before connecting the LED.

**DA**   
**DA**   
 wire prep. 0.75-1.5mm<sup>2</sup>  
 Preparation for input and output: 8-9mm  
**LED+**   
**LED-**   
 wire prep. 0.5-1.0mm<sup>2</sup> **MADE IN CHINA**

Pin(w) typ.	Prated(w)	Irated(mA)	Voltage(Vdc)	Switch			
				1	2	3	4
28.5	28.00	250	6-84	ON	ON	ON	ON
29.5	29.30	275	6-84	ON	ON	ON	ON
28.1	25.20	300	6-84	ON	ON	--	ON
30.4	27.30	325	6-84	--	--	ON	ON
32.7	29.40	350	6-84	ON	ON	--	ON
35.0	31.50	375	6-84	ON	ON	--	ON
37.2	33.60	400	6-84	ON	ON	--	ON
39.6	35.70	425	6-84	--	--	--	ON
41.9	37.80	450	6-84	ON	ON	ON	--
45.5	42.00	500	6-84	ON	ON	ON	--
46.4	43.80	500	6-75	ON	ON	ON	--
46.8	42.00	600	6-70	--	--	ON	--
46.6	43.60	600	6-64	ON	ON	--	--
47.2	43.00	700	6-60	ON	ON	--	--
47.5	42.00	730	6-54	ON	ON	--	--
47.1	44.80	800	6-52	--	--	--	--

For Australia and New Zealand, the marking label with "M"   
 For LED Modules use only   
 tc:90°C ta:45°C

BK-DEL042-0800Bd

Pin	Irated	Voltage	1	2	3	4
23.6W	250mA	84VDC	ON	ON	ON	ON
25.9W	275mA	84VDC	--	ON	ON	ON
28.1W	300mA	84VDC	ON	--	ON	ON
30.4W	325mA	84VDC	--	--	ON	ON
32.7W	350mA	84VDC	ON	ON	--	ON
35.0W	375mA	84VDC	--	ON	--	ON
37.2W	400mA	84VDC	ON	--	--	ON
39.6W	425mA	84VDC	--	--	--	ON
41.9W	450mA	84VDC	ON	ON	ON	--
46.5W	500mA	84VDC	--	ON	ON	--
46.4W	550mA	76VDC	ON	--	ON	--
46.8W	600mA	70VDC	--	--	ON	--
46.6W	650mA	64VDC	ON	ON	--	--
47.2W	700mA	60VDC	--	ON	--	--
47.5W	750mA	54VDC	ON	--	--	--
47.1W	800mA	52VDC	--	--	--	--

**ACL/DC+** **BOKE** www.bokedriver.com  
**Dimmable Constant Current LED Driver**  
**MODEL: BK-DEL042-1100Ad**  
**ACN/DC-**   
**INPUT:** 200-240V  $\approx$  0.50/60Hz 0.3A Max  $\lambda$ :0.95  
**OUTPUT:** 6-38V  $\approx$  1100mA 41.8W 50VDC Max.  
 Other ratings see below sheet  
 Do not energize the driver before connecting the LED.

**DA**   
**DA**   
 wire prep. 0.75-1.5mm<sup>2</sup>  
 Preparation for input and output: 8-9mm  
**LED+**   
**LED-**   
 wire prep. 0.5-1.0mm<sup>2</sup> **MADE IN CHINA**

Pin(w) typ.	Prated(w)	Irated(mA)	Voltage(Vdc)	Switch			
				1	2	3	4
21.4	18.90	400	6-42	ON	ON	ON	ON
22.5	19.95	475	6-42	ON	ON	ON	ON
23.6	21.00	500	6-42	ON	ON	ON	ON
24.8	22.05	525	6-42	--	--	ON	ON
25.9	23.10	550	6-42	ON	ON	ON	ON
28.2	25.20	600	6-42	ON	ON	ON	ON
30.6	27.30	650	6-42	ON	ON	ON	ON
32.9	29.40	700	6-42	--	--	ON	ON
35.2	31.50	750	6-42	ON	ON	ON	ON
37.6	33.60	800	6-42	ON	ON	ON	ON
39.9	35.70	850	6-42	ON	ON	ON	ON
42.3	37.80	900	6-42	ON	ON	ON	ON
44.7	39.90	950	6-42	ON	ON	ON	ON
47.1	42.00	1000	6-42	ON	ON	ON	ON
47.3	40.80	1100	6-38	ON	ON	ON	ON

For Australia and New Zealand, the marking label with "M"   
 For LED Modules use only   
 tc:90°C ta:45°C

BK-DEL042-1100Ad

Pin	Irated	Voltage	1	2	3	4
21.4W	450mA	42VDC	ON	ON	ON	ON
22.5W	475mA	42VDC	--	ON	ON	ON
23.6W	500mA	42VDC	ON	--	ON	ON
24.8W	525mA	42VDC	--	--	ON	ON
25.9W	550mA	42VDC	ON	ON	--	ON
28.2W	600mA	42VDC	--	ON	--	ON
30.6W	650mA	42VDC	ON	--	--	ON
32.9W	700mA	42VDC	--	--	--	ON
35.2W	750mA	42VDC	ON	ON	ON	--
37.6W	800mA	42VDC	--	ON	ON	--
39.9W	850mA	42VDC	ON	--	ON	--
42.3W	900mA	42VDC	--	--	ON	--
44.7W	950mA	42VDC	ON	ON	ON	--
47.1W	1000mA	42VDC	--	ON	--	--
47.3W	1050mA	40VDC	ON	--	--	--
47.3W	1100mA	38VDC	--	--	--	--

**ACL/DC+** **BOKE** www.bokedriver.com  
**Dimmable Constant Current LED Driver**  
**MODEL: BK-DEL060-2000Ad**  
**ACN/DC-**   
**INPUT:** 200-240V  $\approx$  0.50/60Hz 0.4A Max  $\lambda$ :0.95  
**OUTPUT:** 6-30V  $\approx$  2000mA 60W 50VDC Max.  
 Other ratings see below sheet  
 Do not energize the driver before connecting the LED.

**DA**   
**DA**   
 wire prep. 0.75-1.5mm<sup>2</sup>  
 Preparation for input and output: 8-9mm  
**LED+**   
**LED-**   
 wire prep. 0.5-1.0mm<sup>2</sup> **MADE IN CHINA**

Pin(w) typ.	Prated(w)	Irated(mA)	Voltage(Vdc)	Switch			
				1	2	3	4
37.4	33.6	800	6-42	ON	ON	ON	ON
42.0	37.8	900	6-42	--	ON	ON	ON
46.7	42.0	1000	6-42	ON	--	ON	ON
49.1	44.1	1050	6-42	--	--	ON	ON
51.5	46.2	1100	6-42	ON	ON	--	ON
53.8	48.3	1150	6-42	--	ON	--	ON
56.1	50.4	1200	6-42	ON	--	--	ON
58.3	52.5	1250	6-42	--	--	--	ON
60.8	54.6	1300	6-42	ON	ON	ON	--
65.5	58.8	1400	6-42	--	ON	ON	--
67.1	60.0	1500	6-40	ON	--	ON	--
68.2	60.8	1600	6-38	--	--	ON	--
68.9	61.2	1700	6-36	ON	--	--	--
69.2	61.2	1800	6-34	--	ON	--	--
69.1	60.8	1900	6-32	ON	--	--	--
68.6	60.0	2000	6-30	--	--	--	--

For Australia and New Zealand, the marking label with "M"   
 For LED Modules use only   
 tc:90°C ta:45°C

BK-DEL060-2000Ad

Pin	Irated	Voltage	1	2	3	4
37.4W	800mA	42VDC	ON	ON	ON	ON
42.0W	900mA	42VDC	--	ON	ON	ON
46.7W	1000mA	42VDC	ON	--	ON	ON
49.1W	1050mA	42VDC	--	--	ON	ON
51.5W	1100mA	42VDC	ON	ON	--	ON
53.8W	1150mA	42VDC	--	ON	--	ON
56.1W	1200mA	42VDC	ON	--	--	ON
58.3W	1250mA	42VDC	--	--	--	ON
60.8W	1300mA	42VDC	ON	ON	ON	--
65.5W	1400mA	42VDC	--	ON	ON	--
67.1W	1500mA	40VDC	ON	--	ON	--
68.2W	1600mA	38VDC	--	--	ON	--
68.9W	1700mA	36VDC	ON	ON	--	--
69.2W	1800mA	34VDC	--	ON	--	--
69.1W	1900mA	32VDC	ON	--	--	--
68.6W	2000mA	30VDC	--	--	--	--

**Remarks:**

- ★ It means that this item is the factory default current.
- It means that this channel is OFF.

## DALI dimming application

### Wiring diagram

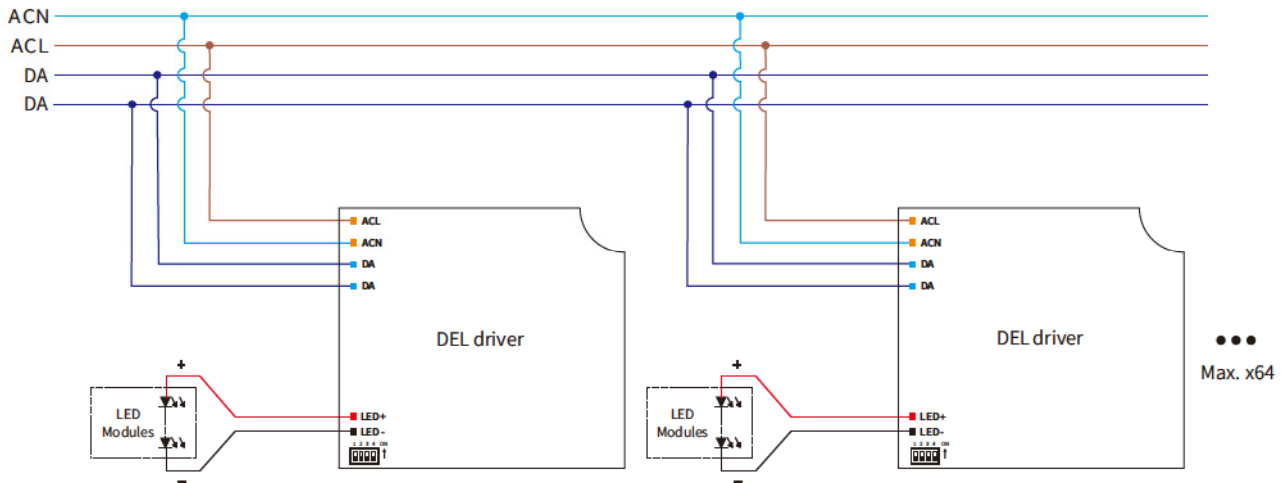

### Activating DALI dimming mode

- After installation according to the wiring diagram of DALI dimming application, the driver will automatically switch to the DALI control mode after receiving any DALI command.

#### Remarks:

- Standard DALI control line voltage range: 9.5V to 22.5V, type 16V.
- The two DALI control lines polarity-reversible.
- Max. 64 DALI drivers per DALI control line.
- The maximum distance length of the DALI control line is 300m at  $2 \times 1.5\text{mm}^2$ .
- DALI bus can be wired together with any mains voltage cables, but separate wiring is recommended.
- The configuration parameters of the driver can be set through the DALI configuration tool or DALI application controller during installation, such as setting device address, group address, power-on level, bus-failure level, scene level, fade time, dimming curve, etc.

Please refer to the table below

Cable size	Distance
$2 \times 0.50\text{mm}^2$	max.100m
$2 \times 0.75\text{mm}^2$	max.150m
$2 \times 1.00\text{mm}^2$	max.200m
$\geq 2 \times 1.50\text{mm}^2$	max.300m

#### Power-on level :

When the driver is in DALI-2 dimming mode, the factory default level after each power-on is the brightest.

The power-on level can be set through the DALI configuration tool or DALI application controller during installation, and can be set to memory or fixed any brightness (such as off, darkest, 50%, etc.).

Note: The recommended setting for the default factory power-on level of the DALI-2 driver is the brightest in the DALI-2 standard.

#### Dimming curve

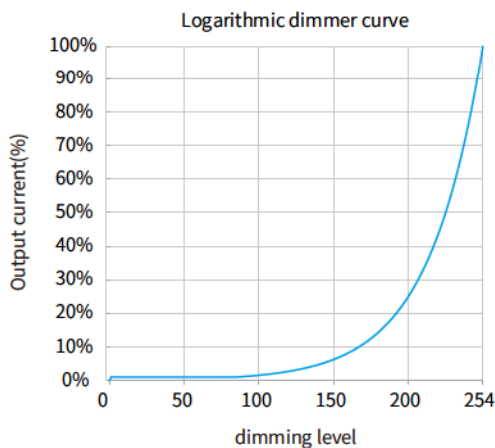

Remarks: The dimming curve can be selected by DALI configuration. The default is logarithmic dimming curve.

**PUSH dimming application**

**Wiring diagram**

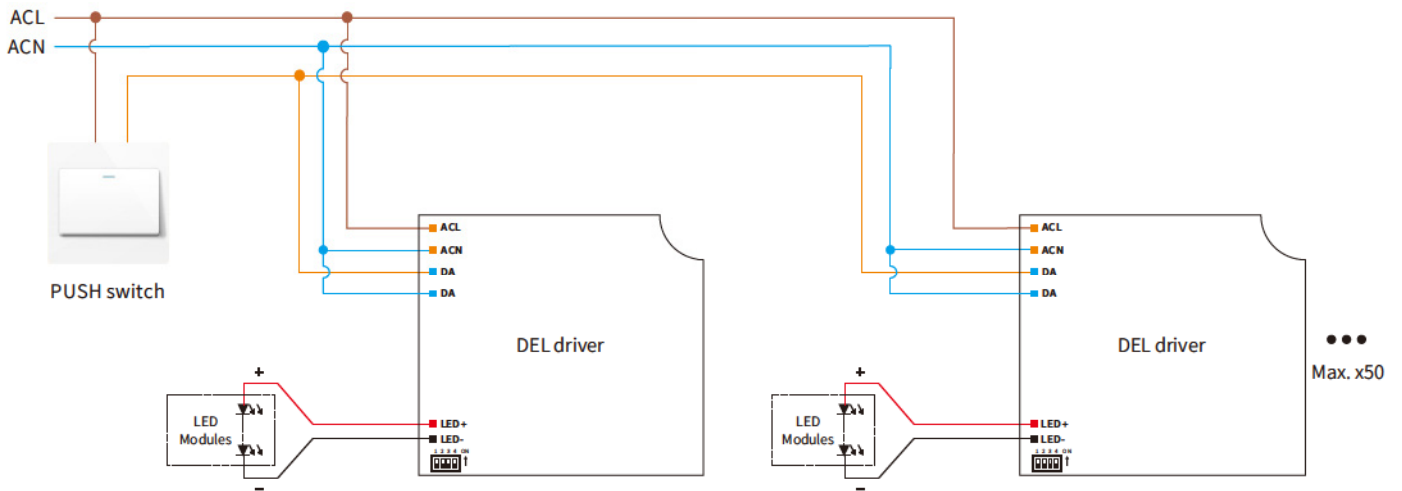

**Activating PUSH dimming mode**

- After installation according to the wiring diagram of PUSH dimming application, short press the PUSH switch 1 times, the driver will automatically switch to PUSH dimming mode.

**Remarks:**

Max. 50 drivers per PUSH control line.

Turn on or turn off: short press push switch for 0.2-1s.

Dimming: long press push switch for 1-5s.

Power on status: after power on, the light state will be the same as the lighting on state.

If the light is on before power off, the light will be on after power on again, brightness will be the same as the last lighting on brightness.

If the light is off before power off, the light will be off after power on again, short press the push button, then the light will be on, the brightness will be the same as the last brightness.

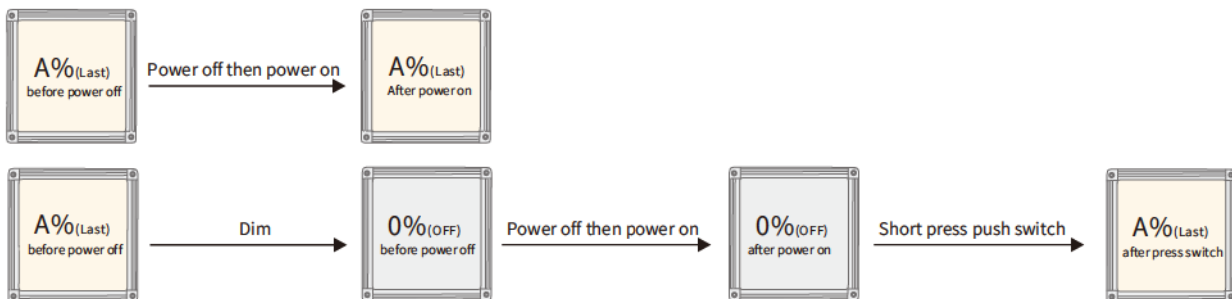

**Multiple lights synchronize control operation**

**method 1:**

Step 1: long press the PUSH switch, confirm each light is on.

Step 2: short press the PUSH switch, confirm each light is off.

Step 3: long press the PUSH switch, confirm each light is from darkest to brightest and all the lights are synchronous.

**method 2:**

- Long press the PUSH switch 15s, all lights output to the brightest state.

**Installation**

**Mechanical dimensions**

Unit:mm

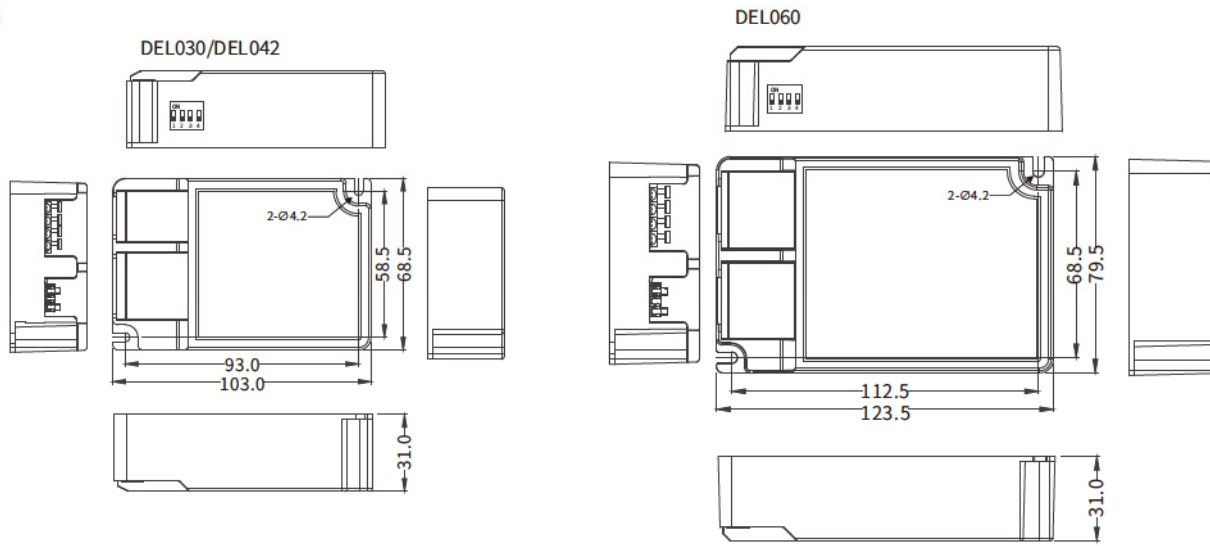

**INPUT**

Pin Numbering	function	colour
1	ACL	orange
2	ACN	orange
3	DA	blue
4	DA	blue

**Input wire**

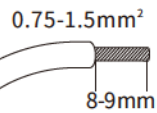

**OUTPUT**

Pin Numbering	function	colour
1	LED+	red
2	LED-	black

**Output wire**

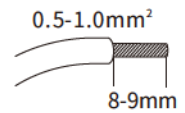

**Installation note**

**Hot plug-in**

- Hot plug-in is not supported due to residual output voltage of > 0V.
- If a LED load is connected the device has to be restarted.
- This can be done via mains reset or via interface (DALI).

**Wiring guidelines**

- All connections must be kept as short as possible to ensure good EMI behaviour.
- Mains leads should be kept apart from LED Driver and other leads (ideally 5 – 10 cm distance)
- Max. length of output wires is 2 m.
- Incorrect wiring can damage LED modules.

**Mounting screw specifications and torque**

- Max. torque at the clamping screw: 0.5 Nm / M4

**Replace LED module**

1. Mains off
2. Remove LED module
3. Wait for 5 seconds
4. Connect LED module again

## Packaging

### Optional 1: factory default

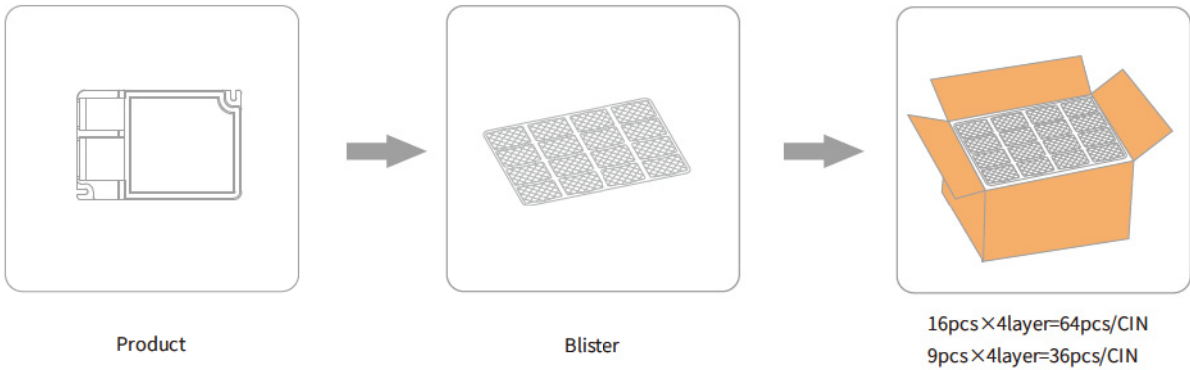

Model	Product size	Weight	Blister size	Carton size	Qty/carton	N.W	G.W
DEL030	L103*W68.5*H31mm	170g	L480*W330*H40mm	L490*W340*H165mm	64pcs	10.9kg	12.5kg
DEL042	L103*W68.5*H31mm	170g	L480*W330*H40mm	L490*W340*H165mm	64pcs	10.9kg	12.5kg
DEL060	L123*W78.5*H31mm	245g	L435*W345*H40mm	L450*W350*H180mm	36pcs	8.82kg	10.5kg

### Optional 2:



Model	Product size	Weight	Packaging size	Carton size	Qty/carton	N.W	G.W
DEL030	L103*W68.5*H31mm	170g	L130*W38*H85mm	L415*W330*H190mm	48pcs	8.20kg	9.70kg
DEL042	L103*W68.5*H31mm	170g	L130*W38*H85mm	L415*W330*H190mm	48pcs	8.20kg	9.70kg
DEL060	L123*W79.5*H31mm	245g	L140*W40*H100mm	L380*W295*H220mm	36pcs	8.82kg	10.5kg

### Additional information

1. This product can only be used outside the light body, Can not be used inside of the light, and it must be used within the specified working environment.
2. The life and MTBF of the product are for reference only, and do not represent a warranty statement. If the drive has been turned on, there is no warranty.
3. For more information, please send an email to [info@bokedriver.com](mailto:info@bokedriver.com).