

This product contains a light source of energy efficiency class < https://www.3f-filippi.com/en/Search >
Questo prodotto contiene una sorgente luminosa di classe di efficienza energetica < https://www.3f-filippi.com/it/Ricerca >
Ce produit contient une source lumineuse de classe d'efficacité énergétique < https://www.3f-filippi.com/fr/Recherche >
Dieses Produkt enthält eine Lichtquelle der Energieeffizienzklasse < https://www.3f-filippi.com/de/Suche >
Este producto contiene una fuente de luz de clase de eficiencia energética < https://www.3f-filippi.com/es/Busqueda >

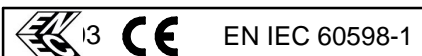

cod.	3F Linux S	Kg
A20011	3F Linux S NL L3556	3.5
A20012	3F Linux S NL L1778	1.7
A20017	3F Linux S 5P L3556	4.0
A20019	3F Linux S 5P L1778	2.0
A20024	3F Linux S 7P L3556	4.2
A20026	3F Linux S 7P L1778	2.2

3F Linux S

3F Linux S NL

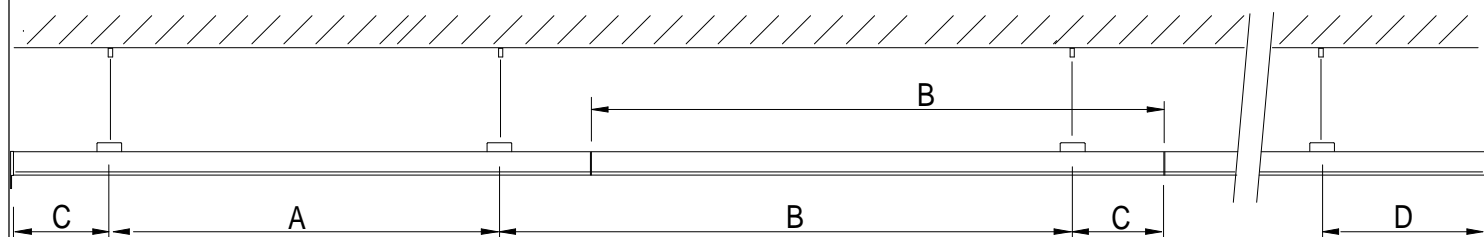
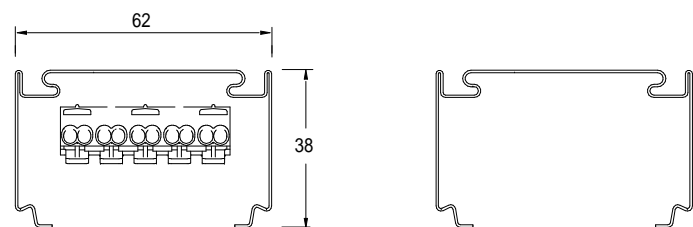

3F Linux S	A	B	C	D
L 1778	1078	1778	200 ÷ 500	200 ÷ 500
L 3556	2856	3556	200 ÷ 500	500 ÷ 1000

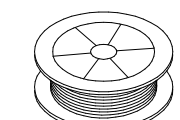
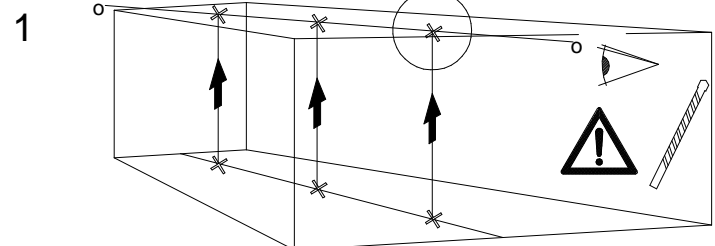
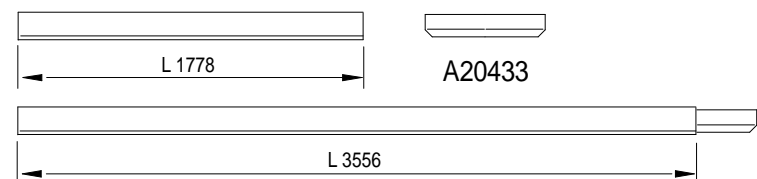

A0716 : mt 100
A0717 : mt 500
A0718 : mt 1000

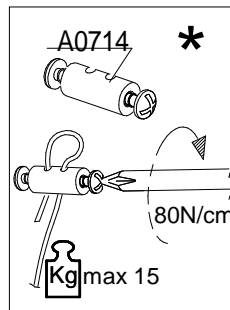

1/A

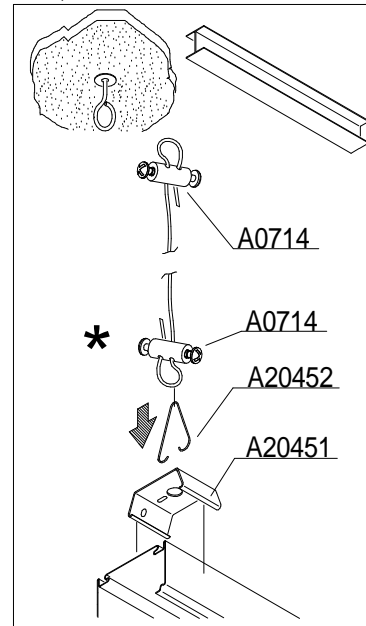
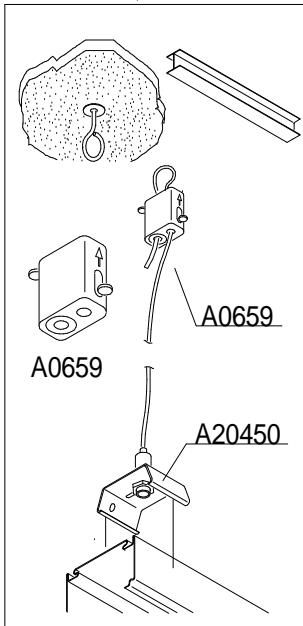
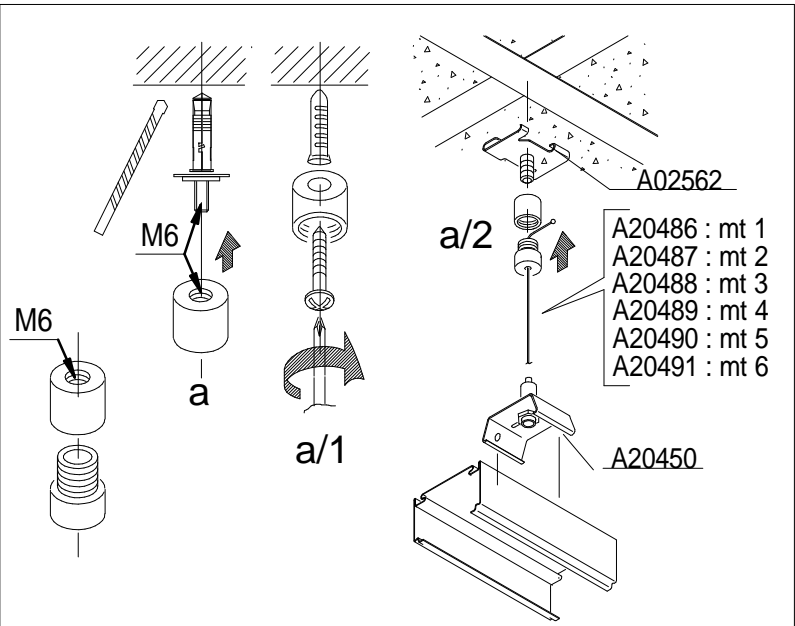

- A20486 : mt 1
- A20487 : mt 2
- A20488 : mt 3
- A20489 : mt 4
- A20490 : mt 5
- A20491 : mt 6

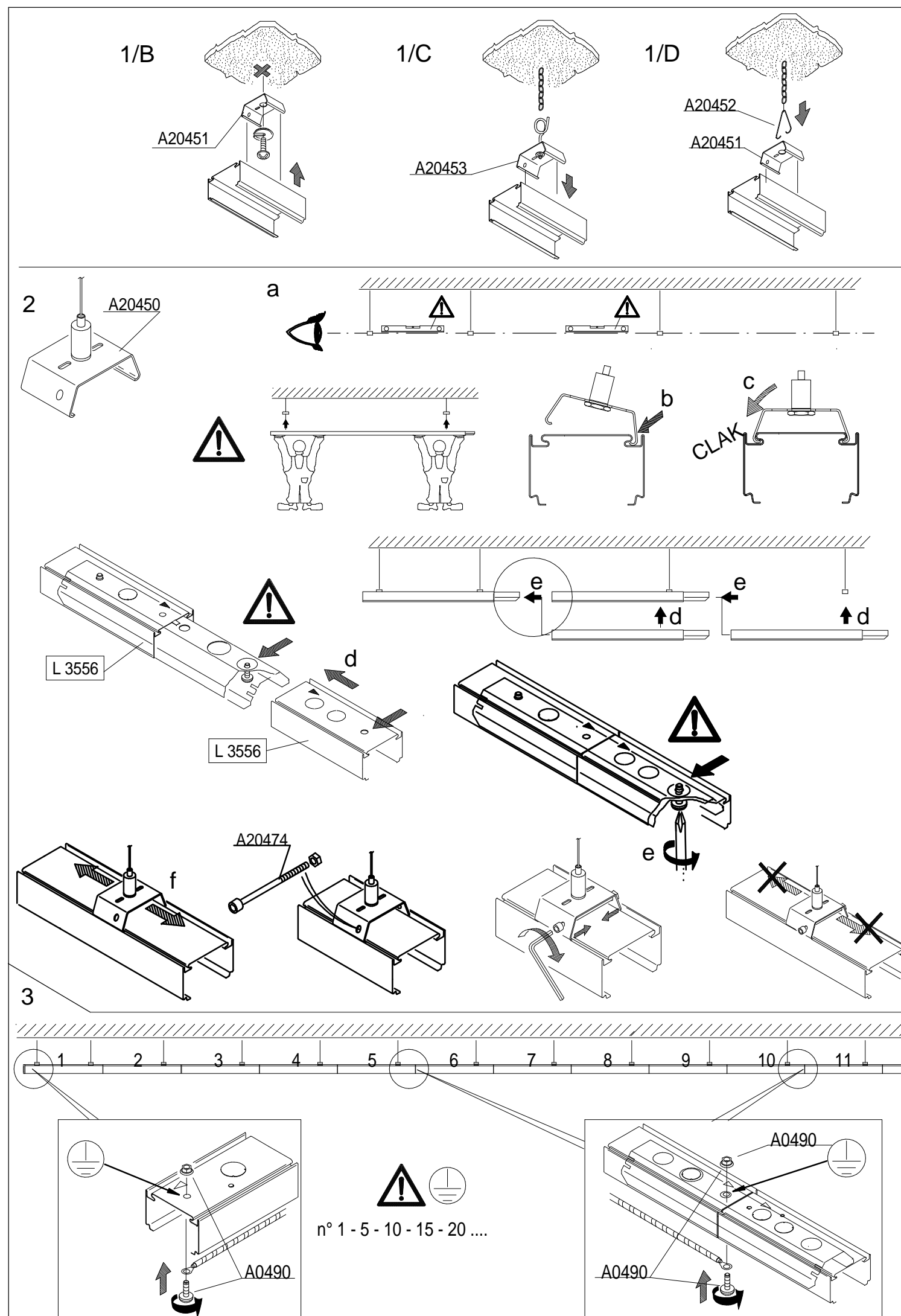

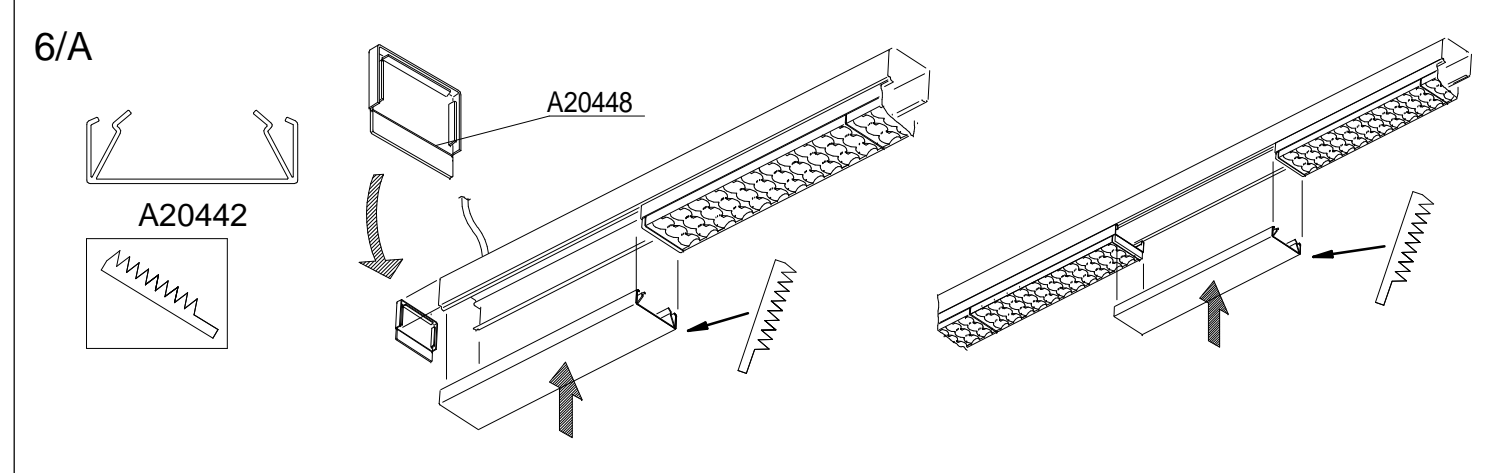
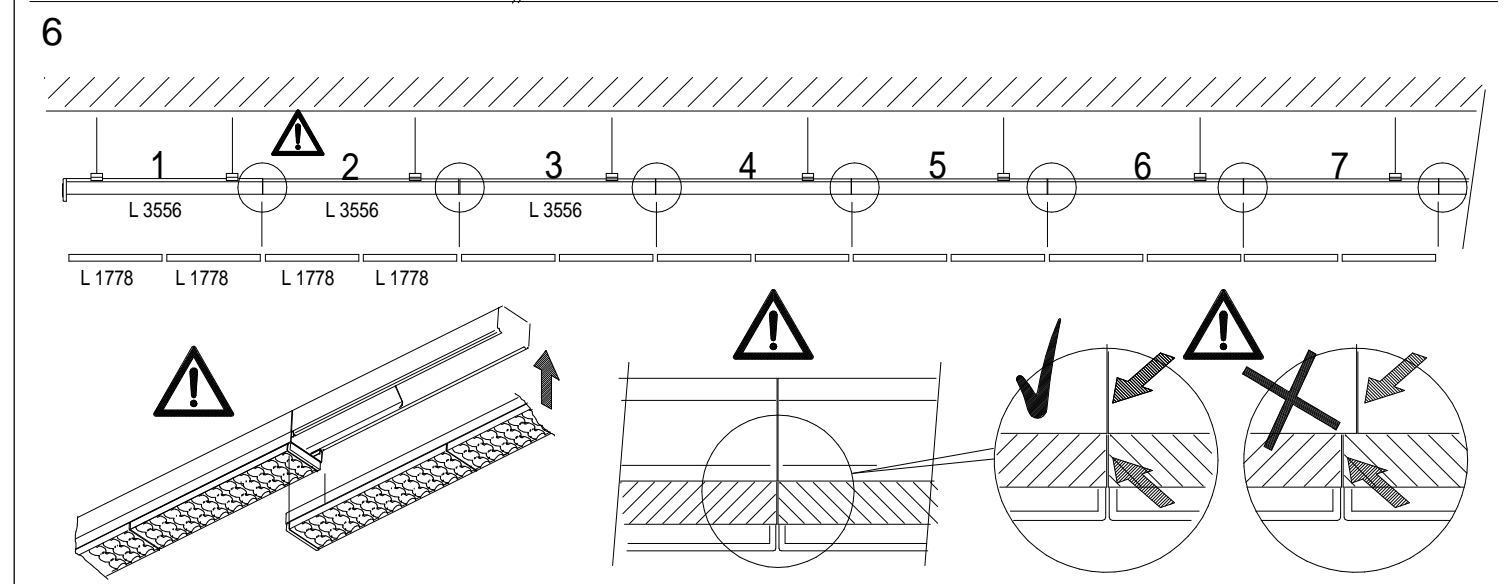
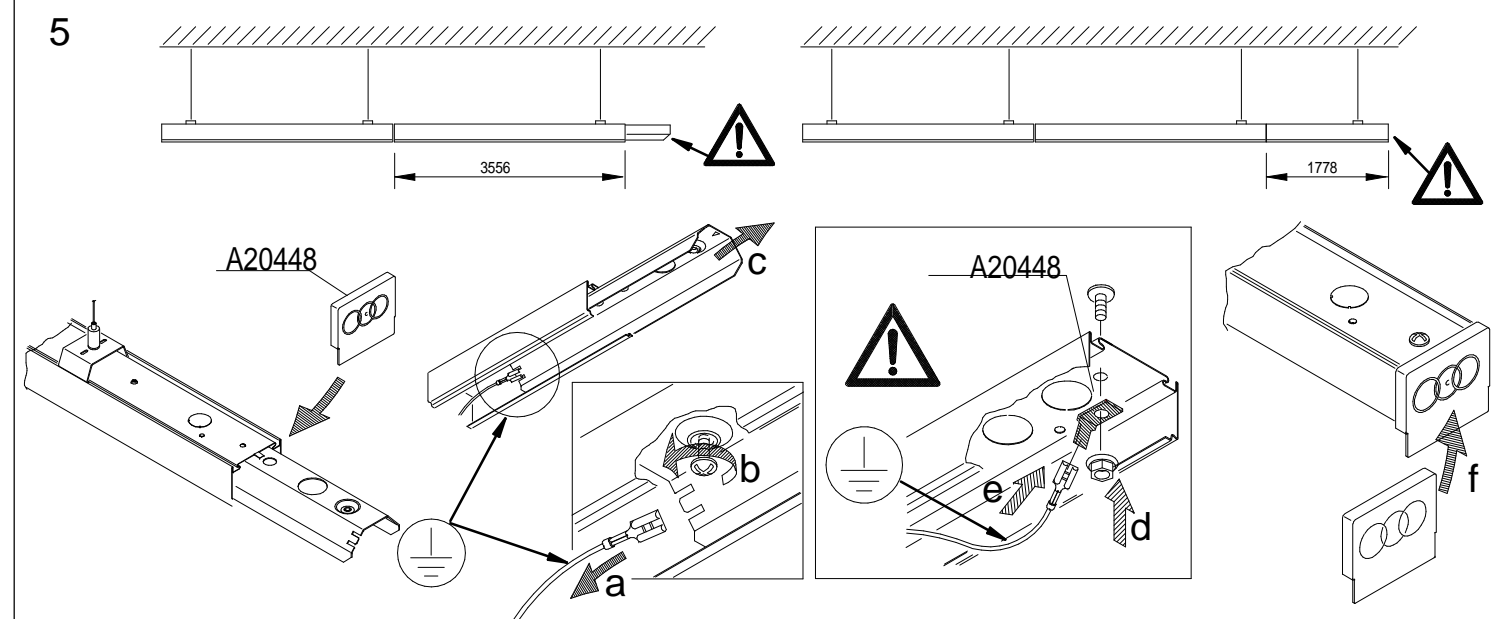
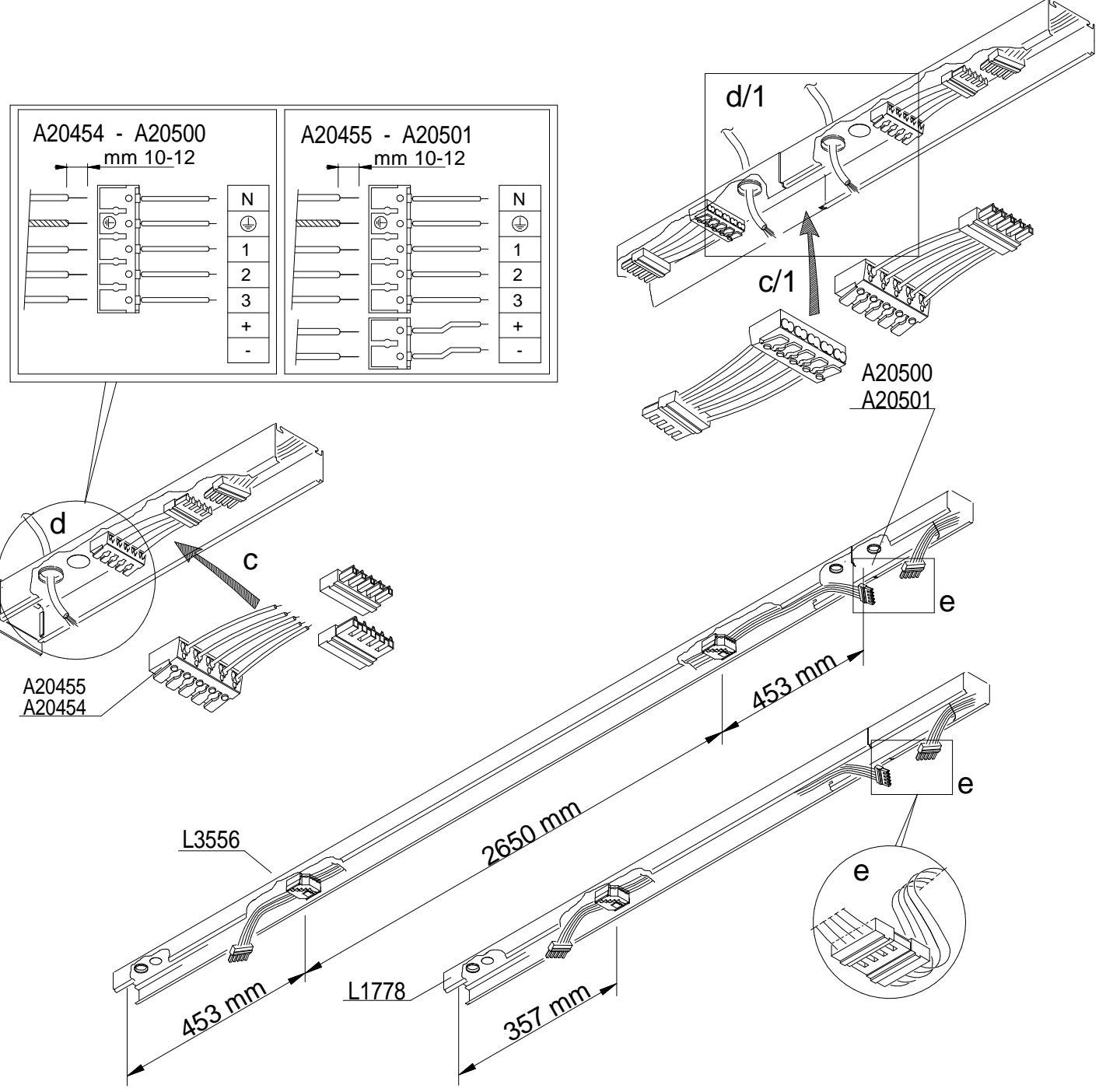
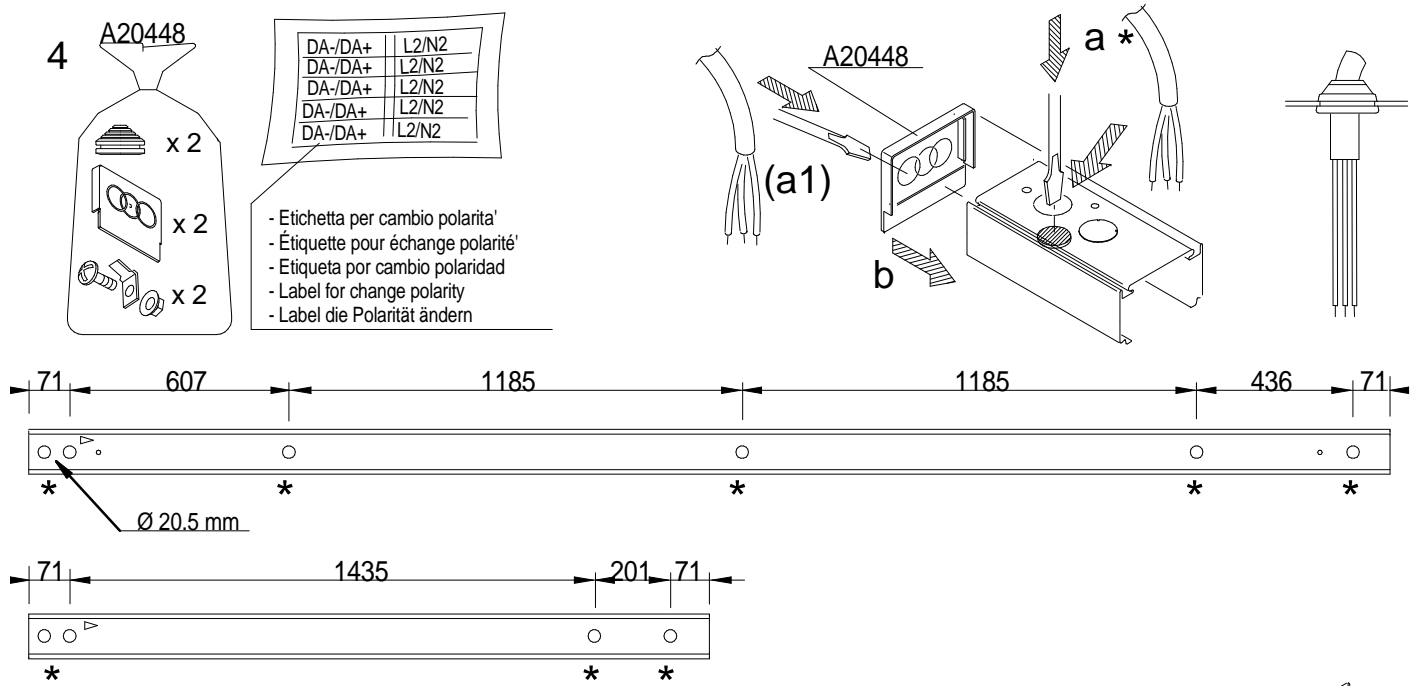

Sorgente luminosa (solo LED) sostituibile da un professionista
 Replaceable (LED only) light source by a professional
 Source lumineuse (LED uniquement) remplaçable par un professionnel
 Fuente luminosa reemplazable (solo LED) por un profesional
 Austauschbare (nur LED) Lichtquelle durch einen Fachmann

Alimentatore sostituibile da un professionista
 Replaceable control gear by a professional
 Boîtier de commande remplaçable par un professionnel
 Equipo de control reemplazable por un profesional
 Austauschbare Vorschaltgeräte durch einen Fachmann

L'apparecchio non deve essere smaltito come rifiuto urbano, mediante cassonetto, ma è soggetto a raccolta separata.
 Il mancato rispetto di questa norma è sanzionato dalla legge e potrebbe provocare potenzialmente effetti negativi sia per l'ambiente sia sulla salute umana.
 L'appareil ne doit pas être éliminé comme ordures ménagères, dans la poubelle, mais il est sujet à collecte sélective.
 La non-observation de cette disposition est sanctionnée par la loi et peut provoquer en puissance effets négatifs soit pour l'ambiance soit pour la santé humaine.
 La luminaria no debe ser desechada como residuo urbano, sino a través de un gestor de residuos, ya que es objeto de recogida selectiva.
 El incumplimiento de esta norma está sancionado por la ley y puede causar potencialmente daños tanto al medio ambiente como a la salud.

The luminaire must not be eliminated as urban waste, by means of refuse body, rather it is object of separate collection.
 The non-observance of this rule is sanctioned by the law and potentially could cause negative effects both on the environment and on human health.
 Die Leuchte muss als Sondermüll entsorgt werden!
 Die Nichteinhaltung dieser Bestimmung kann strafrechtlich verfolgt werden.
 Ferner verursacht eine nicht gerechte Entsorgung negative Folgen für die Umwelt und die menschliche Gesundheit.

DECRETO LEGISLATIVO 14 marzo 2014, n. 49. Attuazione della direttiva 2012/19/UE (Revisione della Direttiva 2002/96/UE) e s.m.i

